

A, D, F, AND H ARE REQUIRED PER ORDER

8	4-1/2	5-3/4	10	1/4				
6-1/2	3-1/4	4-3/4	8	1	8-1/4	5-3/4	10	0
5-1/4	2	3	6	2-1/4	7-1/2	4-3/4	8	0
	MINIMUM	MAXIMUM						
<b>A</b>	<b>B</b>	<b>C</b>	<b>K</b>	<b>X</b>	<b>B</b>	<b>C</b>	<b>K</b>	
MINIMUM EFFECTIVE HEADER	HEADER TO TOP OF TRACK	HORIZONTAL TRACK RADIUS	HANG DOWN	MINIMUM HEADER W/ NO HANG DOWN	HEADER TO TOP OF TRACK	HORIZONTAL TRACK RADIUS	HANG DOWN	

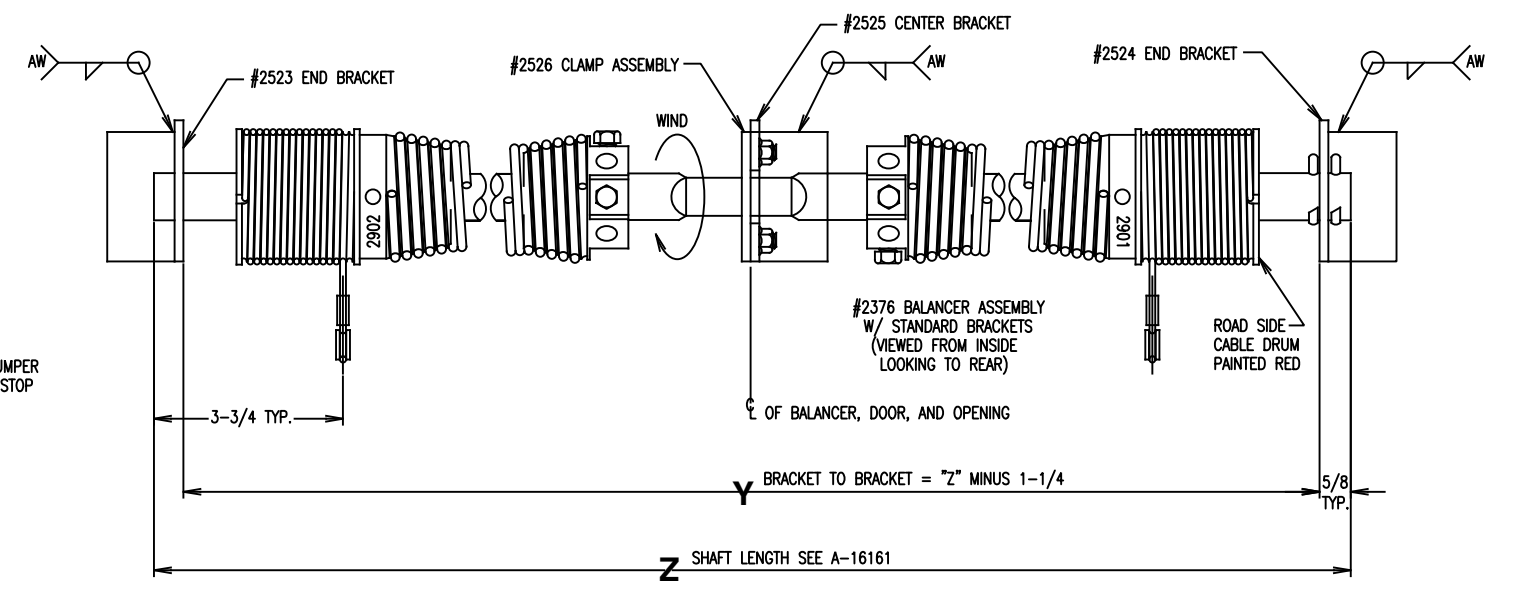

BALANCER NOTES: "Z" MINIMUM = SPRING LENGTH X 2 PLUS 22  
= "C" DIMENSION LESS 2-1/2  
"Y" DIMENSION MAY BE PROVIDED PER ORDER

CURB SIDE

ROAD SIDE

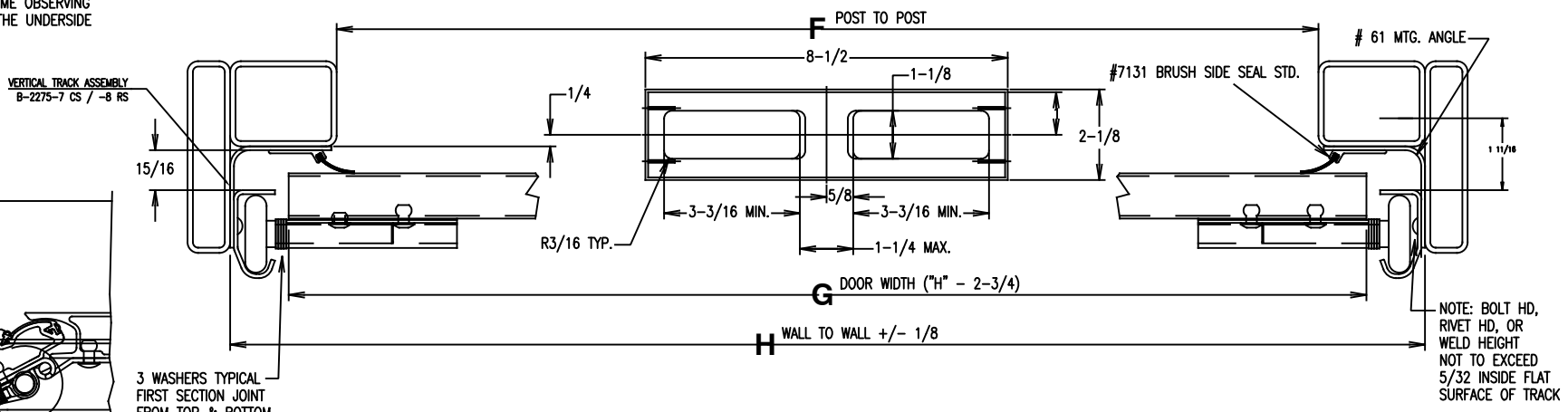

3 WASHERS TYPICAL FIRST SECTION JOINT FROM TOP & BOTTOM 4 LOCATIONS TOTAL FOR 1/4 - 3/8 OF SIDE SHIFT

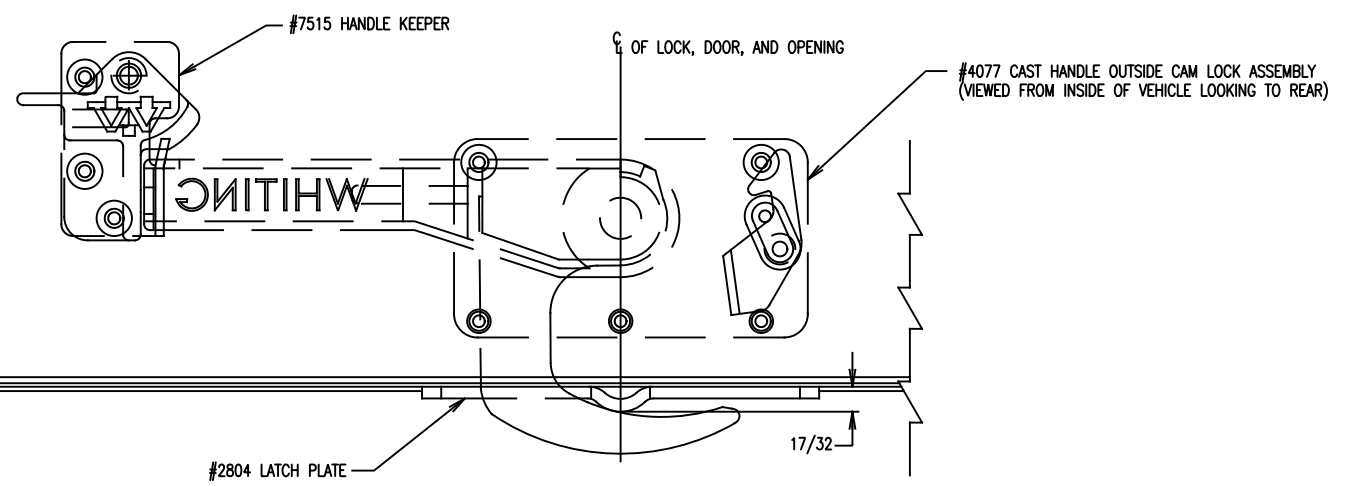

STANDARD SPEC.: B-15819

DATE	SYM	DESCRIPTION OF CHANGE	AUTH	DR
6/13/12	E	ADDED VERTICAL TRACK ASSEMBLY PART NUMBERS	GB	KCL
3/31/09	D	CORRECTED CHART, REMOVED NO HANG DOWN FOR 6" RADIUS	MJS	AF
9/15/08	C	CORRECTED BOTTOM PANEL VIEW; RADIUS "C" WAS LABELED "X"	MJS	AF
2/5/08	B	UPDATED TOP BRACKET VIEW; AND 6" RADIUS CHART: A, B, K, X, AND B DIMS	MJS	GB
10/8/06	A	HOR. TRACK LENGTH WAS S-H + 18"	MJS	GB

TOLERANCES UNLESS OTHERWISE SPECIFIED ARE:  
DECIMAL ±0.10  
FRACTION ±1/16  
ANGLES ±1/2°

WHITING DOOR MANUFACTURING LTD.  
3435 SOUTH SERVICE ROAD  
BURLINGTON, ONTARIO L7N 3W6

DRAWN BY DCW DATE 4/20/05 CHECKED DATE TERRITORY

APPROVED BY DATE TERRITORY

SCALE	DWG. NO.	REV.
1/2"=1"	D-15296	E